



INDUMICRO.com

Industrial Micro Computers



IMD-A1x0

12"/15"/17"/19" Industrial Monitor

- ✓ Front Panel NEMA 4/IP 65 rated
- ✓ Steel chassis & front panel
- ✓ OSD controls on back side
- ✓ Auto phase / Auto position
- ✓ Optional resistive touch screen



DESCRIPTION

The IMD-A1x0 series industrial monitors with either a 12" SVGA (300 cd/m²), a 15" XGA (400 cd/m²), a 17" SXGA (300 cd/m²) or a 19" SXGA (250cd/m²) TFT LCD are the perfect fit for monitoring and control applications.

The 'T' version additionally offers a resistive touch screen.

The OSD buttons are situated on the back so the settings can't be changed accidentally.

The front panel of the display monitor is sealed with a gasket for NEMA 4/IP65 rating when it is mounted in a NEMA rated cabinet or enclosure.

FEATURES

- ✓ Color Active TFT Flat Panel Display
- ✓ Optional resistive touch screen or vandal proof SecureTouch touch screen
- ✓ Black painted steel front panel* with NEMA 4/IP 65 rating
- ✓ VGA input (optional DVI/S-Video/RCA input)
- ✓ Auto phase / Auto position
- ✓ OSD controls on back side
- ✓ 90~240 VAC power input (optionally 12/24 VDC power input)

* Other colors available on request

Indumicro.com bv | P.O. Box 589 | NL-6710 BD Ede

+31 (0) 318 668 912

sales@indumicro.com | www.indumicro.com

System Specifications

Model:	IMD-A120	IMD-A120T	IMD-A150	IMD-A150T	IMD-A170	IMD-A170T	IMD-A190	IMD-A190T
Display:	12" SVGA TFT 800 x 600 300 cd/m ² 262K colors		15" XGA TFT 1024 x 768 400 cd/m ² 16.2M colors		17" SXGA TFT 1280 x 1024 300 cd/m ² 16.2M colors		19" SXGA TFT 1280 x 1024 250 cd/m ² 16.2M colors	
Viewing Angle:	120° (H), 95° (V)		170° (H), 135° (V)		170° (H), 135° (V)		140° (H), 140° (V)	
Backlight Lifetime:	50,000 hrs							
Touch Screen:	None	Resistive	None	Resistive	None	Resistive	None	Resistive
OSD Controls/Indicators:	Automatic Screen, Setup (OSD), Brightness, Contrast, Horizontal/Vertical Position, Image Lock, Color Balance, Video Information, Power On and Sync							
Ports:	VGA	VGA USB	VGA	VGA USB	VGA	VGA USB	VGA	VGA USB
Power Input:	90~240 VAC (optionally 12/24 VDC power input)							

Mechanical Specifications

Construction:	Heavy-duty steel chassis, IP-65 certified steel front panel			
Color:	Black front panel / beige housing			
Mounting:	Panel mount			
Operating Temperature:	0~50°C			
Storage Temperature:	-20°C~60°C			
Vibration:	5 - 17Hz, 0.1" double amplitude displacement; 17 - 640Hz, 1.5G acceleration peak to peak			
Shock:	10G acceleration peak to peak (11ms)			
EMC:	FCC/CE Class A certified			
Dimensions (W/H/D):	390 x 264 x 63mm	410 x 310 x 69mm	457 x 355 x 75mm	484 x 400 x 71.7mm

Dimensions

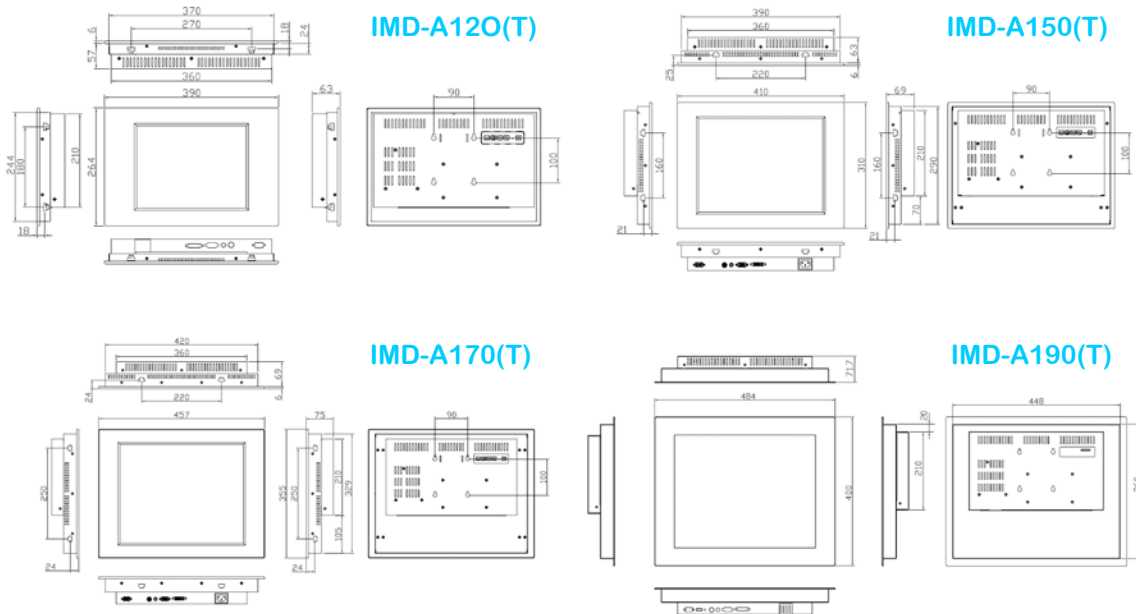

Upgrades/Accessories

IMU-AD0V1 Upgrade to DVI/S-Video/RCA input
IMU-ADCC 12/24V power input instead of 90~240VAC

IMU-AxxSS Upgrade to xx" stainless steel front panel
IMU-AxxGFG Upgrade to xx" SecureTouch

Disclaimer: Published configurations and performance specifications are subject to change without prior notice. While due caution has been exercised in the production of this document, possible errors and omissions are unintentional.